

XAG FBV Smart Electric Valve Controller (Internal Antenna) User Manual

Version 1.0 **EN**

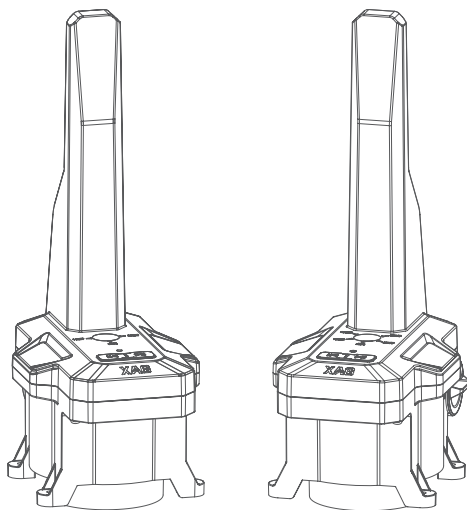

To User

Dear user, thank you for choosing XAG's products.

For safety purposes and better user experience, it is highly recommended that you read this manual carefully and strictly follow the instructions hereof.

Contact Us

Manufacturer: Guangzhou Xaircraft Technology Co., Ltd.

Add: XSpace, No.115, Gaopu Road, Guangzhou, Guangdong Province, China

Technical Support Team: support@xa.com

Introduction

The XAG FBV Smart Electric Valve Controller (Internal Antenna), hereinafter referred to as the "controller", is part of the 2025 XAG Smart Farm series. Compatible with various XAG smart electric valve body models, including FBV2, FBV3, and FBV5, it meets multi-scenario operational needs. With the "XAG Farm" app, users can easily manage irrigation. This makes it a powerful tool for modern smart farm management.

List of Items^[1]

Please see that all of the following items are present when unpacking the box. Should there be any item missing, please contact your seller immediately.

FBV2i Smart Electric Valve Controller

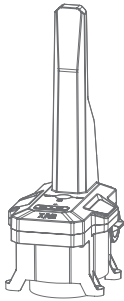

FBV2i Smart Electric Valve Controller
x 1

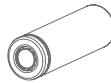

Battery
x 1



Sensor Connector
x 1

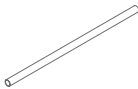

Air Tube
x 1



M5 Screw
x 4

[1]: Packaging and item lists vary depending on the model of the controller you select. Different models of controllers are compatible with different types of electric valve bodies. The FBV2i, FBV3i, and FBV5i controllers must be respectively paired with the FBV2, FBV3, and FBV5 electric valve bodies. Please purchase the model that meets your operational needs.

FBV3i Smart Electric Valve Controller

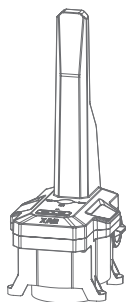

FBV3i Smart Electric Valve Controller
x 1

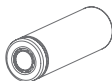

Battery
x 1



Sensor Connector
x 2

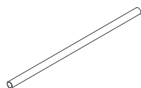

Air Tube
x 2



M5 Screw
x 4

FBV5i Smart Electric Valve Controller

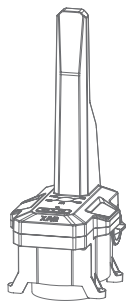

FBV5i Smart Electric Valve Controller
x 1

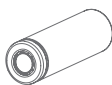

Battery
x 1



Sensor Connector
x 2

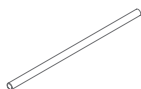

Air Tube
x 2



M5 Screw
x 4

Main Components

FBV2i Smart Electric Valve Controller

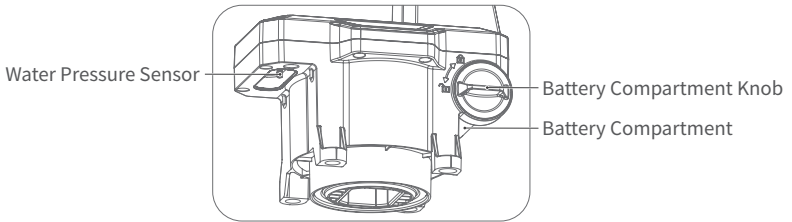
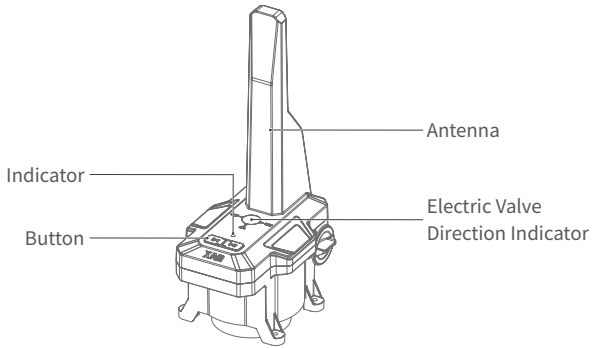

Side View

FBV3i Smart Electric Valve Controller

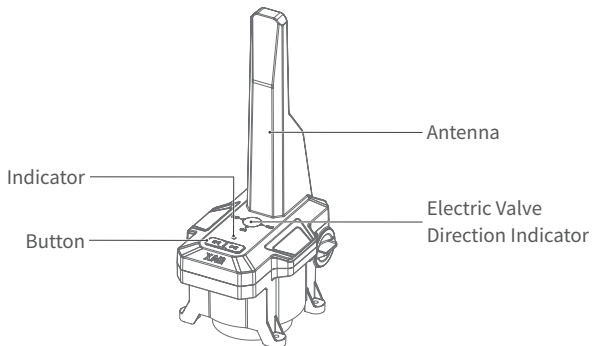

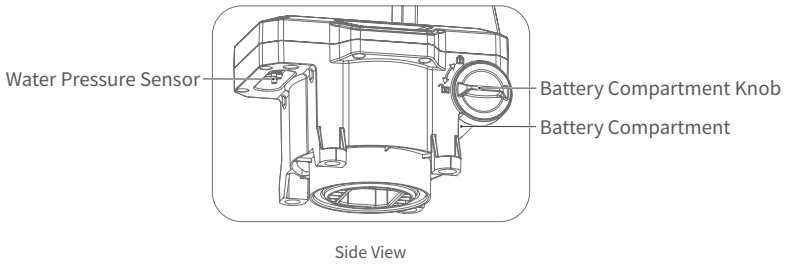

FBV5i Smart Electric Valve Controller

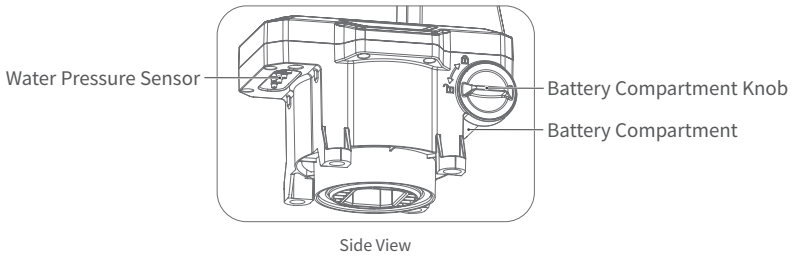
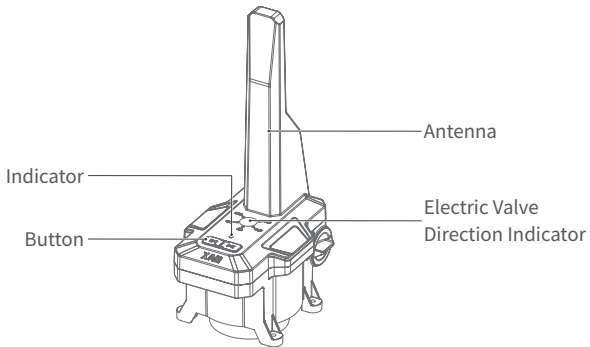

Button Description

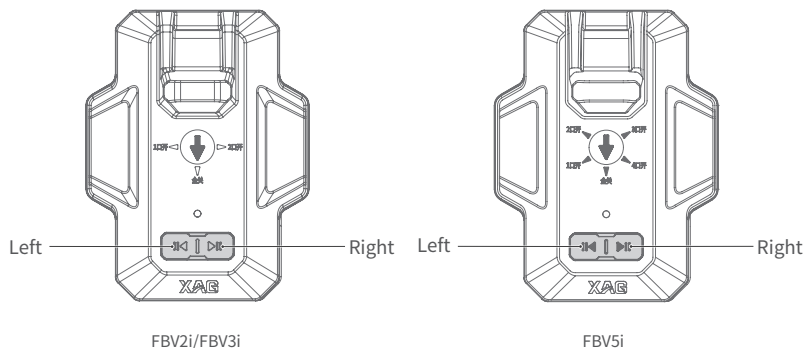

Action	Description
Short press left/right button (in sleep mode)	Wake up device
Short press left button (in wake-up mode)	Electric valve rotates clockwise / stops
Short press right button (in wake-up mode)	Electric valve rotates counterclockwise / stops
Press both left and right buttons for 5 seconds	Enter networking mode

Indicator Description

Status Indicator	Description
Off	Standby mode, device sleeps
Solid Yellow	Device waiting to connect / reconnecting
Slow Flashing Yellow	Connecting to network
Solid Red	Device fault (connection failure / network failure / disconnection)
Solid Green	Device online
Slow Flashing Green	Data uploading
Fast Flashing Green	Executing command, motor runs when the button is pressed
Slow Flashing Blue	Bluetooth waiting to connect

Installation

Install Controller

Align the controller with the locking boss of the smart electric valve body and secure it with four M5 screws (the diagram shows an electric valve with hose connectors as an example).

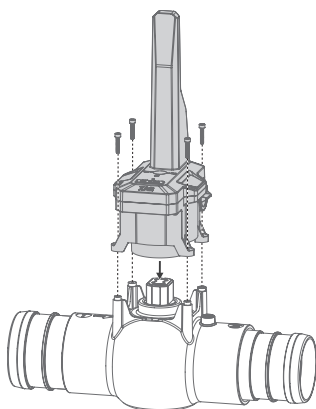

FBV2i

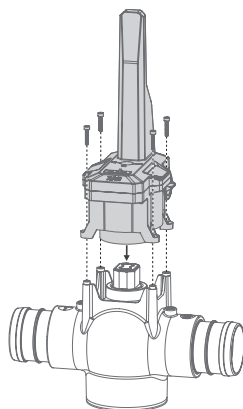

FBV3i

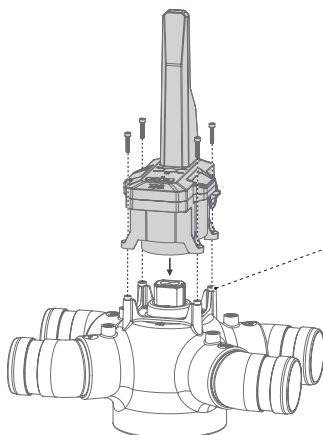

FBV5i

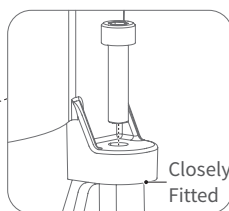

Note

- ⚠ When tightening the fixing screws, avoid using excessive force to prevent damaging the controller or the smart electric valve body.
- ⚠ Different models of controllers are designed exclusively for their corresponding smart electric valve body models. Do not mix them.

Assemble Smart Electric Valve

- ① Connect and tighten the sensor connector to the water pressure sensor port of the smart electric valve.
- ② Remove the dust cap from the pagoda connector of the controller's water pressure sensor.
- ③ Connect the air tube between the controller and the smart electric valve body to complete the installation of the smart electric valve (the diagram shows a smart electric valve with hose connectors as an example).

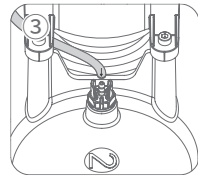
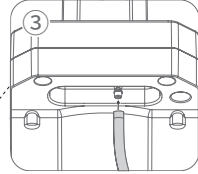
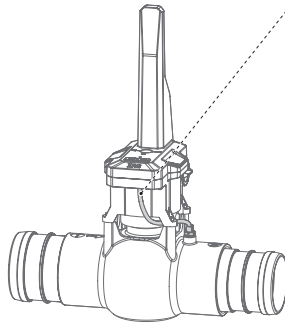
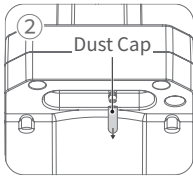
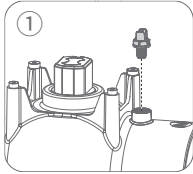

FBV2 Smart Electric Valve

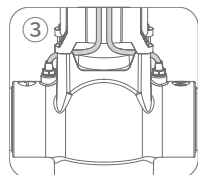
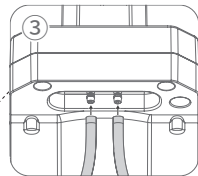
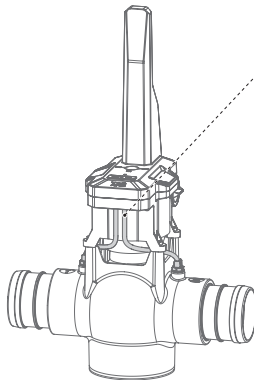
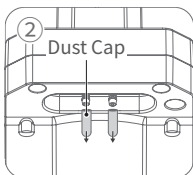
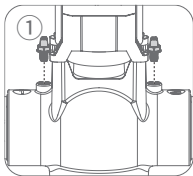

FBV3 Smart Electric Valve

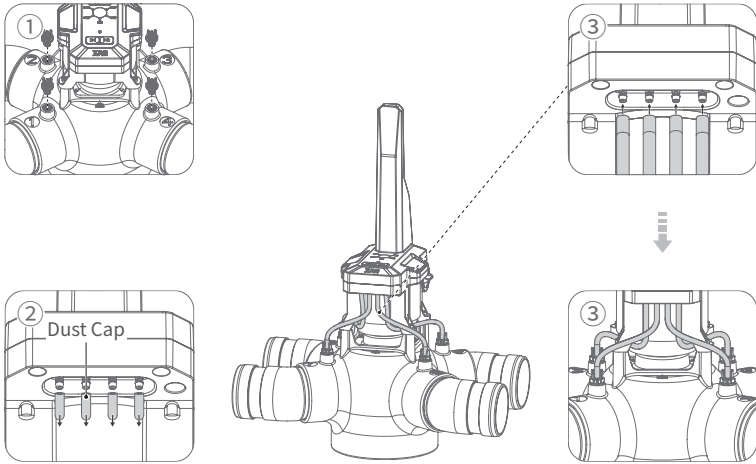

FBV5 Smart Electric Valve

Note

- ⚠ Before installing the air tube, ensure that no water or dust enters the pagoda connector of the water pressure sensor, as this could lead to inaccurate water pressure measurement.
- ⚠ When installing the air tube, follow the illustrated position strictly to avoid causing a malfunction of the device.

Install Smart Electric Valve

FBV2 Smart Electric Valve

Place the FBV2 Smart Electric Valve horizontally on the ground, and connect hoses to the outlets on both sides to complete the installation (the diagram shows an FBV2 with hose connectors as an example).

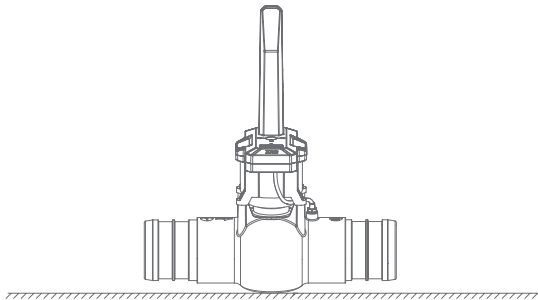

FBV3 / FBV5 Smart Electric Valve

① Choose installation based on the type of inlet connector.

For threaded connector: Wrap Teflon tape around the male thread connector^[1] and secure it on the PVC pipe. Then, connect and tighten the FBV3 / FBV5 onto the male thread connector by rotating clockwise.

For rigid pipe connector: Connect the FBV3 / FBV5 to the PVC pipe and secure it using PVC pipe adhesive.

② Connect hoses to the outlets on both sides and fix them with hose clamps, completing the installation of FBV3 / FBV5 (the diagram shows a smart electric valve with hose connectors as an example).

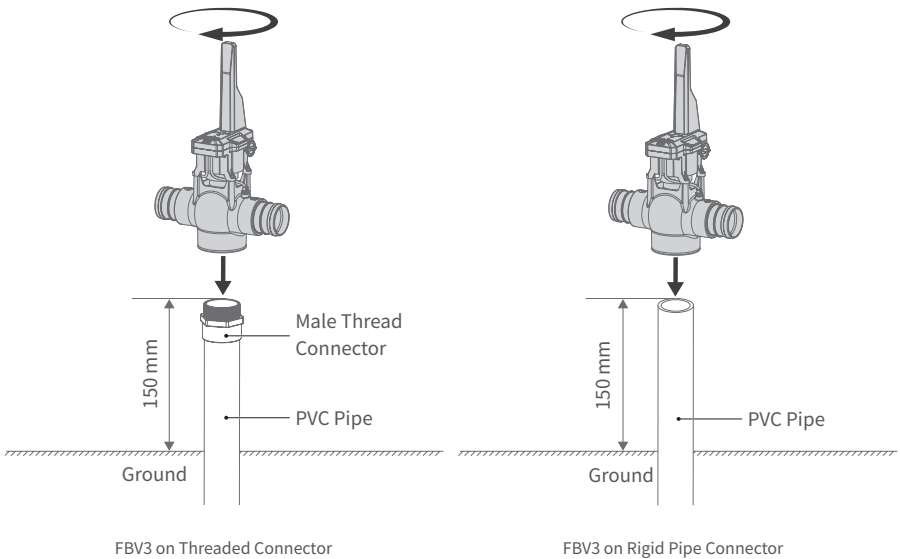

[1]: The male thread connector must be purchased from XAG's official sources. Using non-compliant, unqualified, or incompatible connectors may result in poor performance or even damage to the smart electric valve. Users will be responsible for any resulting losses.

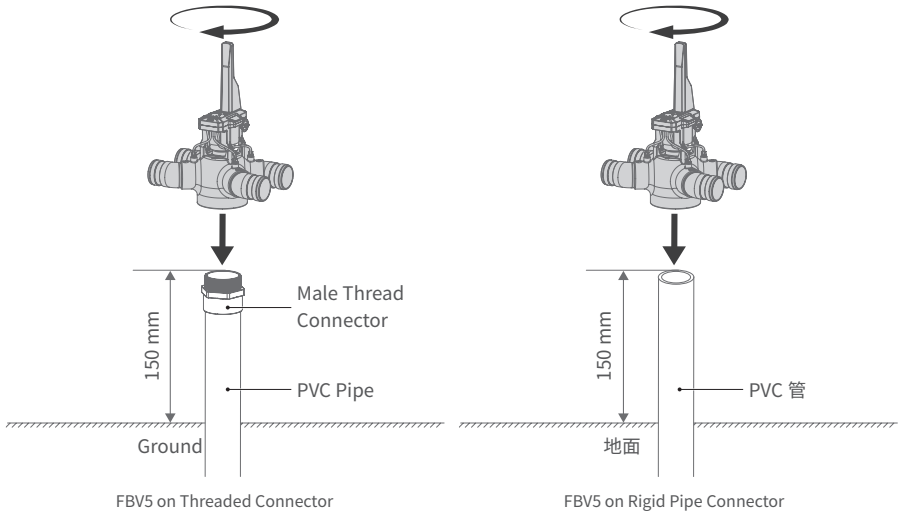

Note

- ⚠ Ensure that the smart electric valve is installed within the coverage area of the farm's network. Otherwise, it may not function properly due to network connection failure.
- ⚠ The smart electric valve must be installed vertically on the ground.
- ⚠ After installation, remove weeds or clutter around the smart electric valve, ensuring that the area within 1 meter remains unobstructed.

Install Battery

- ① Remove the battery compartment knob by rotating it counterclockwise.
- ② Insert the battery (with the **negative terminal** facing inward). Reattach the battery compartment knob and tighten it clockwise to complete the battery installation.

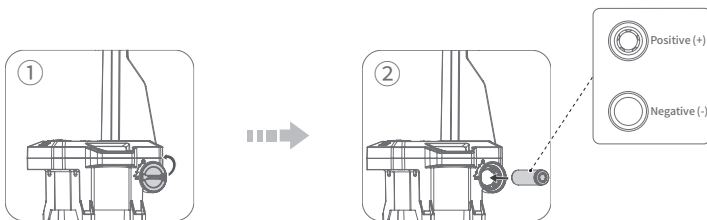

Warning

- ⚠ Please carefully check the battery terminals to ensure correct installation. For the first installation, ensure the battery is fully charged.
- ⚠ Only **21700** ternary lithium-ion rechargeable batteries should be used. Do not use other types of batteries.
- ⚠ Do not use batteries that are swollen, or have damaged insulation protection.

Post-Installation Check

1. Check if the air tube connected to the water pressure sensor is loose.
2. Check if the smart electric valve is secure. The valve and the PVC pipe must be tightly connected to prevent movement of the device.
3. After waking up the smart electric valve, check if the ball valve operates normally by pressing the buttons.

How to Use

Download "XAG Farm" App







Android Users: Scan the QR code above to download and install the "XAG Farm" App

iOS Users: Search for "XAG Farm" in the App Store to download and install

Add Device

When using the smart electric valve for the first time, please add the device in the "XAG Farm" App. Users can follow these steps to add the smart electric valve.

1. Open the "XAG Farm" App, enter your phone number to register, and log in to your account.
2. Press and hold both the left and right buttons of the smart electric valve for more than 5 seconds, and release when the indicator light starts flashing blue. The smart electric valve will enter networking mode.
3. In the "Farm  " screen, tap  in the top-right corner, select "Add Device  " (or in the "Farm" -> "Device", tap  on the right side and select "Add Device"). The App will automatically scan for devices.
4. After the device is successfully scanned, tap "Add" and then "Confirm"^[1].
5. It will prompt "Added", indicating that the smart electric valve has been added.



[1]: If the added device is an FBV3 smart electric valve, select the current valve type (T-type or L-type) as prompted on the screen before tapping "Confirm".

Note

- ⚠ Before adding the device, please ensure that the farm network has been set up and that the local server has been added in the "XAG Farm" App. For installation and usage of the local server, please refer to the "XAG FS1 Local Server User Manual" or "XAG FS2 Local Server User Manual".
- ⚠ Before adding the device, please make sure the "XAG Farm" App is updated to the latest version.
- ⚠ Before adding the device, ensure there are no obstacles between the smart electric valve and the local server or wireless relay. Also, make sure that the phone positioning is enabled, and that the "XAG Farm" App has permission for positioning and Bluetooth access.
- ⚠ When adding the device, keep the phone close to the device and ensure Bluetooth is enabled to scan nearby devices.



Set Device Location

After successfully adding the smart electric valve, a pop-up reminder will appear on the map to set the valve's location. Tap "Go to Settings" to add the location information for the smart electric valve. After adding the device's location, if you need to manage the device's location, tap  in the top-right corner to edit the device's location. Users can follow these steps to adjust the smart electric valve's location.

1. Open the "XAG Farm" App, tap the Device List in the "Farm  " screen, select the smart electric valve to operate, and enter the Operation Details screen for that valve.
2. Tap  in the top-right corner to enter the Device Info screen.
3. Drag the map to select the location to place.
4. Once the smart electric valve icon is aligned with the location on the map, tap "Save" to complete the device location setup.



Device Settings

Before using the smart electric valve, you can pre-set its functions. Users can follow these steps to set the device.

1. Open the "XAG Farm" App, tap the Device List in the "Farm  " screen, then  on the right side, and select "Device Settings".
2. In the "Device Settings" screen, you can set "Automatically enter Power-saving Mode when open for extended periods" and "Water Pressure Monitoring".
3. Tap "Automatically enter Power-saving Mode when open for extended periods" to set the time interval for the smart electric valve to enter Power-saving Mode. To meet the requirements of the scenes, the device has two working modes: Power-saving Mode and Performance Mode. The system will automatically switch to "Power-saving Mode" when the valve is closed and "Performance Mode" when it is open.
4. Tap "Water Pressure Monitoring" to enable/disable Water Pressure Monitoring in this screen, or set threshold values for high/low water pressure alerts. When enabled, the system will automatically monitor and notify if the water pressure is too high or too low.

Control Smart Electric Valve





After adding the smart electric valve, users can follow these steps to operate the valve.

1. Open the "XAG Farm" App, in the "Overview  " screen, tap the valve you want to control on the map to enter its operation screen (or in the "Farm  " screen, tap the Device List, select the valve, and go to its Operation Details screen).
2. Select the port you want to adjust, then tap the corresponding switch button to open/close the port. When the port is open, you can tap "Settings" to adjust its opening.^[1]
3. In the smart electric valve's Operation Details screen, you can view the water pressure trend. Tap "View More" to access the calendar and view the historical water pressure trends for each port. You can also view the "Action History" records on this screen, and tap "View More" to view historical operation records from other dates.

[1]: The next time you open it, it will default to the current opening.

Create Irrigation Group

When batch management of multiple devices is required, you can use the Irrigation Group function. By creating an irrigation group, you can easily open or close multiple smart electric valves within the group in batch, enabling remote and efficient irrigation. After setting the irrigation group scene, irrigation reports will be generated, allowing you to track every detail of the irrigation process.

1. Open the "XAG Farm" App, tap  in the top-right corner in "Scene  " screen, and select to add the scene "Irrigation Group".
2. After adding, the new irrigation group will appear in the "Scene  " screen. Tap the new irrigation group  to rename, edit, or delete it.
3. In the "Scene  " screen, tap the new irrigation group, select the smart electric valves you want to associate, and tap the valve to select the ports you want to control. After selection, tap "Save".
4. Once set up, tap to enter this irrigation group screen to batch control the smart electric valves and monitor the water pressure during the irrigation process.

Maintenance

- Regularly check the battery. Replace it promptly if there is leakage or swelling.
- Regularly check the air tubes connected to the water pressure sensor for looseness or damage.
- Regularly check and clean the mud, sand, and other debris accumulated inside the electric valve body to prevent pipeline blockages.
- When pesticides, fertilizers, or other substances that may cause corrosion are present around the electric valve, please clean it promptly with a cleaning agent.
- In harsh working conditions, maintenance intervals should be appropriately shortened.

Transport and Storage

- Before transporting smart electric valves, the battery must be removed from the controller's battery compartment.
- When transporting smart electric valves, please wrap them tightly with shock-absorbing materials to prevent collisions or accidents during transportation.
- When transporting the battery, it must be securely placed. Please wrap the battery tightly with shock-absorbing materials to prevent collisions or accidents during transportation.
- Do NOT place the battery near heat sources or in high-temperature (above 45 °C) sealed environments, such as a hot, sealed vehicle or cabin.
- Do not transport the battery while it is hot. Wait for the battery to cool to room temperature before transportation.
- The environment for transporting the battery should be dry (ambient air humidity should be kept below 75%). Do NOT place the battery in a damp environment.
- Do NOT place or transport the battery with flammable, explosive materials, or metal objects.
- Do NOT charge or discharge the battery during transportation.
- Do NOT transport batteries that are swollen, leaking, or visibly damaged, as they may pose safety hazards.
- When the controller is idle, remove the battery from the battery compartment and store it horizontally in a safe, cool place after the valve is cleaned.
- Do not mix normal batteries with faulty batteries.
- Store the battery in an open environment, ensuring there are no flammable materials, debris, or devices that may cause electrical sparks (such as charging devices, electrical switches, or power sources) within a 10-meter radius.
- The battery storage area must be clearly designated and marked, and should be managed by designated personnel.

Battery Safety Instructions

- The battery should be used in an environment with a temperature range of 0 ° C to 45 ° C. Using the battery in high temperatures (above 45° C) may cause the battery to catch fire or even explode.
- Do NOT connect the battery's positive and negative terminals with wires or other metal objects, as this may cause a short circuit.
- If the battery terminals have liquid or foreign objects, clean them immediately and keep the terminals dry and clean to prevent poor contact, which could lead to energy loss or charging failure.
- Handle the battery with care. Do NOT disassemble, puncture, or apply pressure to the battery, including but not limited to the actions that apply pressure to the battery or cause external stress on it.
- Regularly check the exterior of battery. Do NOT clean charging devices with flammable agents. Do NOT use damaged charging devices.
- When charging, ensure that the charging device is placed in an environment free of flammable, explosive, or combustible materials, and avoid charging in a closed, confined space. A responsible person must be present during charging to prevent accidents.
- The battery should be stored in a dry environment with an appropriate temperature^[1]. Do not store the battery in places exposed to water, humidity, or direct sunlight.

- The liquid inside the battery is highly corrosive. If the liquid comes into contact with skin or eyes, immediately flush with water and seek medical attention.
- If a short circuit occurs during charging, immediately disconnect the power supply and place the battery on the ground or in a fire bucket. Use an asbestos blanket (or equivalent material) to cover the battery flames and extinguish them by covering with fireproof sand to isolate the air.
- When disposing of the battery, comply with local laws and regulations and do NOT discard the battery arbitrarily.

[1]: Battery Storage Temperature: -20° C to 23° C (more than 3 months, less than 1 year), -20° C to 45° C (more than 1 month, less than 3 months), -20° C to 60° C (within 1 month).

Precautions

- Before the first use of the smart electric valve, ensure its battery is installed.
- Before operation, please ensure that both the firmware and the "XAG Farm" app are up to date.
- Never remove or fit any components while the smart electric valve is in operation.
- The internal water flow is under high pressure while the smart electric valve is in operation. Do not shake the valve body or pull the water hose. Keep children away from the valve and hose.
- Ensure the valve body is installed horizontally to the ground to prevent malfunctions or poor performance.
- Never insert or remove the battery while the smart electric valve is in operation.
- When using the valve body, ensure that the water is free from impurities such as mud, sand, or plant debris to prevent leakage.
- Keep the battery compartment's connector clean and avoid contact with metals, electrolytes, corrosive liquids, or any foreign objects that could damage the battery or conductive contacts.
- Strictly follow the installation and usage guidelines for the battery. Failure to do so may prevent the valve from starting or cause damage. Any resulting financial loss or liability will be the sole responsibility of the user.
- Never modify, disassemble, or reassemble the smart electric valve. Any accidents resulting from modifications to the valve for other purposes will be the user's responsibility.
- Do not submerge the battery compartment in water, and never throw devices with batteries into fire.
- As the smart electric valve may be damaged by animals in the farmland, carefully inspect the pipes and valve body for any damage before operation.
- Always turn off the water pump before inspecting or repairing the smart electric valve.
- Occasional vibrations of the smart electric valve during operation are normal and do not affect the valve's functionality.
- Keep the product away from heat sources to prevent damage to its components or to avoid hazards like fire.
- Any human-caused malfunctions or damage, including those resulting from the user's failure to use, store, transport, or maintain the product in accordance with the user manual, are not covered by the warranty.
- To protect the rights of users outside the Chinese mainland, distributors/dealers, and XAG, products not purchased through officially authorized channels may experience network connectivity issues or usage restrictions outside the Chinese mainland. Please ensure that you purchase XAG products through official channels in your region.

Specifications

General

Control Mode	Electric / Manual
Battery Type	Replaceable Lithium Battery
Power Supply Voltage	DC 3.65 V (Li-ion Battery)
Torque	40 N · m
Water Pressure Sensor Accurac	1.5% FS
Indoor/Outdoor Use	Outdoor
Communication Protocol	Bluetooth / Wi-Fi
Communication Range (Antenna Unobstructed)	≤ 300 m
Operating Temperature	0 ~ 45 °C
Wet Locations (If Applicable)	YES
Relative Humidity	≤ 95 %RH
Pollution Degree of the Intended Environment	2
Installation Height	25 ~ 300 cm above ground level

Model ^[1] Parameters	8WGK-2M40A1	8WGK-3M40B1	8WGK-5M40B1
Operating Pressure	0 ~ 400 kPa	0 ~ 200 kPa	0-200 kPa
Overload Pressure	600 kPa	250 kPa	250 kPa

[1]: This product is available in 3 models. The numbers 2, 3, and 5 in the model names indicate the type of electric valve body the controller is compatible with: 2 represents the FBV2 electric valve body, 3 represents the FBV3 electric valve body, and 5 represents the FBV5 electric valve body. The letters A1 and B1 in the model names indicate the version of the controller, with A1 representing a new product and B1 representing an updated product.

FCC Compliance Notice

Warning: Changes or modifications to this unit not expressly approved by the party responsible for compliance could void the user's authority to operate the equipment.

NOTE: This equipment has been tested and found to comply with the limits for a Class B digital device, pursuant to Part 15 of the FCC Rules. These limits are designed to provide reasonable protection against harmful interference in a residential installation. This equipment generates, uses and can radiate radio frequency energy and, if not installed and used in accordance with the instructions, may cause harmful interference to radio communications.

However, there is no guarantee that interference will not occur in a particular installation. If this equipment does cause harmful interference to radio or television reception, which can be determined by turning the equipment off and on, the user is encouraged to try to correct the interference by one or more of the following measures:

- Reorient or relocate the receiving antenna.
- Increase the separation between the equipment and receiver.
- Connect the equipment into an outlet on a circuit different from that to which the receiver is connected.
- Consult the dealer or an experienced radio/TV technician for help.

This device complies with Part 15 of the FCC Rules. Operation is subject to the following two conditions:

- (1) this device may not cause harmful interference, and
- (2) this device must accept any interference received, including interference that may cause undesired operation.

“FCC RF Radiation Exposure Statement Caution: To maintain compliance with the FCC's RF exposure guidelines, place the product at least 20cm from nearby persons.”

This equipment complies with FCC and Canada & CE radiation exposure limits set forth for an uncontrolled environment. This equipment should be installed and operated with a minimum distance of 20cm between the radiator and your body.

EU Compliance Statement:Guangzhou Xaircraft Technology CO.,LTD.All Rights Reserved.hereby declares that this device is in compliance with the essential requirements and other relevant provisions of the RED Directive. This equipment must be installed and operated in accordance with provide instructions and the antenna used for this transmitter must be installed to provide a separation distance of at least 20cm from all persons and must not be co-located or operation in conjunction with any other antenna or transmitter.End-users and installers must be provide with antenna installation instructions and transmitter operating conditions for satisfying RF exposure compliance.



Warning: Operation of this equipment in a residential environment could cause radio interference.

“Hereby, [Guangzhou Xaircraft Technology CO.,LTD.], declares that this [FBV Smart Electric Valve Controller(Internal Antenna)] is in compliance with the essential requirements and other relevant provisions of 2014/53/EU.

The full text of the EU declaration of conformity is available at the following internet address:
www.xa.com/en/service/downloads”

Suppliers Name(EU): NIK ELECTRONICS LTD

Suppliers Address (EU) : Sofia, 11B Brussels Blvd., fl.13

Suppliers phone number and / or internet contact information: 00359899952228

KCC Warning Message

이 기기는 업무용 환경에서 사용할 목적으로 적합성 평가를 받은 기기로서 가정용 환경에서 사용하는 경우 전파 간섭의 우려가 있습니다 .

FCC Supplier's Declaration of Conformity

Brand name / model number: 8WGK-2M40A1,8WGK-3M40B1,8WGK-5M40B1

This device complies with part 15 of the FCC Rules. Operation is subject to the following two conditions: (1) This device may not cause harmful interference, and (2) this device must accept any interference received, including interference that may cause undesired operation.

Suppliers Name(FCC): Pegasus Spray Inc

Suppliers Address (FCC): 18571 State Hwy 6 Lewistown, MO 63452, United State

Suppliers phone number and / or internet contact information: +1 (503) 866-1228

NCC statement

取得審驗證明之低功率射頻器材，非經核准，公司、商號或使用者均不得擅自變更頻率、加大功率或變更原設計之特性及功能。低功率射頻器材之使用不得影響飛航安全及干擾合法通信；經發現有干擾現象時，應立即停用，並改善至無干擾時方得繼續使用。前述合法通信，指依電信管理法規定作業之無線電通信。低功率射頻器材須忍受合法通信或工業、科學及醫療用電波輻射性電機設備之干擾。

Without permission granted by the NCC, any company, enterprise, or user is not allowed to change frequency, enhance transmitting power or alter original characteristic as well as performance to a approved low power radio-frequency devices. The low power radio-frequency devices shall not influence aircraft security and interfere legal communications; If found, the user shall cease operating immediately until no interference is achieved. The said legal communications means radio communications is operated in compliance with the Telecommunications Management Act. The low power radio-frequency devices must be susceptible with the interference from legal communications or ISM radio wave radiated devices.

減少電磁波影響，請妥適使用。

電波功率密度 MPE 標準值：0.9mW/cm²，送測產品實測值：0.088 mW/cm²，建議使用時設備天線至少距離人體 20 公分。

警告使用者：此為甲類資訊技術設備，於居住環境中使用時，可能會造成射頻騷動，在此種情況下，使用者會被要求採取某些適當的對策。

取得審驗證明之低功率射頻器材，非經核准，公司、商號或使用者均不得擅自變更頻率、加大功率或變更原設計之特性及功能。低功率射頻器材之使用不得影響飛航安全及干擾合法通信；經發現有干擾現象時，應立即停用，並改善至無干擾時方得繼續使用，前述合法通信，指依電信管理法規定作業之無線電通信。低功率射頻器材須忍受合法通信或工業、科學及醫療用電波輻射性電機設備之干擾。

Disclaimer

1. Please read this Disclaimer carefully before using this product, as it has much to do with both operational safety and your legitimate rights and interests. You shall be deemed to have read, known, understood, agreed to, and accepted all the terms and conditions as well as information stated herein upon the use of this product.
2. Not being a toy and with certain safety risks, this product is not suitable for those who are under 18 years old, those who have limited or no capacity for civil conduct, or those with mobility impairments.
3. This product is in the XAG Smart Farm series solely designed for agricultural use. Be sure to read the User Manual carefully before using this product to understand your legitimate rights and interests, responsibilities as well as safety guidelines. Otherwise, property damage and accidents could be caused; personal safety could be at risk.
4. You undertake to use the product within the bounds of the law for legitimate purposes only and agree to the terms and conditions stated herein as well as potential related policies and norms formulated by XAG. You understand and accept that records created during use may be saved to a server. XAG shall resume no responsibility for the failure to save records for any reason attributable to the user.
5. To the maximum extent permitted by law, under no circumstances shall XAG offer an implicit or explicit guarantee for this product, including but not limited to implicit guarantees pertaining to vendibility, fitness for a particular use, or non-infringement.
6. Please install, use, transport, and maintain the product under the instructions in this User Manual. Do NOT modify, convert, or disassemble this product on your own as any malfunction or damage arising therefrom or resulting from your improper use will not be covered by the warranty, and you shall solely assume the liability arising therefrom, both financially and legally.
7. To the maximum extent permitted by law, XAG shall not be liable for any loss caused by your use of this product outside the instructions in this User Manual. Furthermore, XAG shall not be liable for any indirect, consequential, punitive, accidental, special or exemplary damage, including any loss incurred as a result of your purchase, use, or inability to use the product, even if you have been advised of the possibility of such loss.
8. You understand that in the use of any products, accidents may occur as a result of a single or combined factors, including but not limited to improper operation, surroundings and communication networks. You understand that the aforesaid accidents are reasonable and acceptable in the use of the product, and that XAG shall not be held accountable for such accidents.
9. On any account, purchasers or users shall comply with the laws and regulations of the country and region where the product is used. XAG shall assume no liability arising from the violation of the laws and regulations of the location where the product is used by the purchaser or user.
10. As exclusion clauses may be prohibited by certain laws and regulations, your rights may vary. However, this does not imply that certain or all terms contained in this Disclaimer are necessarily invalid. For any reason that partial terms stated herein are deemed void, other terms shall remain in effect.
11. To the extent permitted by law, XAG reserves the right for final explanation and revision of the terms and conditions stated hereinabove. XAG also has the right to update, modify or terminate these terms and conditions via its official website, User Manual, online App, etc., without prior notice.

Warning

Before using this product, user is required to read through the User Manual. Improper operation may cause injury to user or others, or cause damage to the product and property loss, and any financial or legal accountability arising therefrom shall be borne by the user. Safety awareness is of great importance during operation. Please install, maintain, and legally use the product by strictly following the instructions in the User Manual.



overseas@xa.com



@XAGofficial



@xag_official



@XAG Official